

Hybrid Control of an Active Suspension System with Full-Car Model Using H_∞ and Nonlinear Adaptive Control Methods

Trong Hieu Bui*, Jin Ho Suh, Sang Bong Kim

Dept. of Mechanical Eng., College, Pukyong National University San 100, Yongdang-Dong, Nam-Gu, Pusan 608-739, Korea

Tan Tien Nguyen

Dept. of Mechanical Eng., Hochiminh City University of Technology 268 Ly Thuong Kiet Str., Dist. 10, Hochiminh City, Vietnam

This paper presents hybrid control of an active suspension system with a full-car model by using H_∞ and nonlinear adaptive control methods. The full-car model has seven degrees of freedom including heaving, pitching and rolling motions. In the active suspension system, the controller shows good performance: small gains from the road disturbances to the heaving, pitching and rolling accelerations of the car body. Also the controlled system must be robust to system parameter variations. As the control method, H_∞ controller is designed so as to guarantee the robustness of a closed-loop system in the presence of uncertainties and disturbances. The system parameter variations are taken into account by multiplicative uncertainty model and the system robustness is guaranteed by small gain theorem. The active system with H_∞ controller can reduce the accelerations of the car body in the heaving, pitching and rolling directions. The nonlinearity of a hydraulic actuator is handled by nonlinear adaptive control based on the back-stepping method. The effectiveness of the controllers is verified through simulation results in both frequency and time domains.

Key Words : Active Suspension, Full-Car Model, Hydraulic Actuator, H_∞ Control Nonlinear Adaptive Control

Nomenclature

$C.G.$: Center of gravity	$b_{s_{fr}}, b_{s_{fl}}$: Front-right and front-left damping coefficients [Ns/m]
a	: Distance between the C.G. of car-body and front axle [m]	$b_{s_{rr}}, b_{s_{rl}}$: Rear-right and rear-left damping coefficients [Ns/m]
b	: Distance between the C.G. of car-body and rear axle [m]	$k_{s_{fr}}, k_{s_{fl}}$: Front-right and front-left spring stiffness coefficients [N/m]
c	: Half of width of car-body [m]	$k_{s_{rr}}, k_{s_{rl}}$: Rear-right and rear-left spring stiffness coefficients [N/m]
m_s	: Sprung mass (car-body mass) [kg]	$k_{t_{fr}}, k_{t_{fl}}$: Front-right and front-left tire stiffness coefficients [N/m]
$m_{u_{fr}}, m_{u_{fl}}$: Front-right and front-left unsprung masses [kg]	$k_{t_{rr}}, k_{t_{rl}}$: Rear-right and rear-left tire stiffness coefficients [N/m]
$m_{u_{rr}}, m_{u_{rl}}$: Rear-right and rear-left unsprung masses [kg]	F_{fr}, F_{fl}	: Front-right and front-left active forces [N]
		F_{rr}, F_{rl}	: Rear-right and rear-left active forces [N]
		$z_{s_{fr}}, z_{s_{fl}}$: Front-right and front-left displacements of the car-body [m]

* Corresponding Author,

E-mail : hieupknu@yahoo.com

TEL : +82-51-620-1606; FAX : +82-51-621-1411

Dept. of Mechanical Eng., College, Pukyong National University San 100, Yongdang-Dong, Nam-Gu, Pusan 608-739, Korea. (Manuscript Received January 12, 2002; Revised August 26, 2002)

$z_{s_{rr}}, z_{s_{rl}}$: Rear-right and rear-left displacements of the car-body [m]
$z_{u_{fr}}, z_{u_{fl}}$: Front-right and front-left unsprung masses displacements [m]
$z_{u_{rr}}, z_{u_{rl}}$: Rear-right and rear-left unsprung masses displacements [m]
$z_{r_{fr}}, z_{r_{fl}}$: Front-right and front-left road disturbances [m]
$z_{r_{rr}}, z_{r_{rl}}$: Rear-right and rear-left road disturbances [m]
$z_{v_{fr}}, z_{v_{fl}}$: Front-right and front-left servo-valves displacements [m]
$z_{v_{rr}}, z_{v_{rl}}$: Rear-right and rear-left servo-valves displacements [m]
z	: Heaving displacement of the car-body [m]
θ	: Rolling angle of the car-body [rad]
Φ	: Pitching angle of the car-body [rad]
I_x	: Rolling moment of inertia of the car-body about the roll axis [kgm ²]
I_y	: Pitching moment of inertia of the car-body about the pitch axis [kgm ²]
A_f, A_r	: Front and rear piston areas [m ²]
P_{s_f}, P_{s_r}	: Supplied pressures of the fluid of front and rear pistons [N/m ²]
C_{d_f}, C_{d_r}	: Discharge coefficients of front and rear pistons
w_{f_f}, w_{f_r}	: Spool valve area gradients of front and rear pistons
ρ_f, ρ_r	: Hydraulic fluid densities of front and rear pistons
C_{lm_f}, C_{lm_r}	: Total leakage coefficient of the front and rear pistons [m ⁵ /Ns]
β_{e_f}, β_{e_r}	: effective bulk moduli of the front and rear pistons [N/m ²]
V_{t_f}, V_{t_r}	: total actuator volumes [m ³]
τ_f, τ_r	: time constants [sec]
$i_{v_{fr}}, i_{v_{fl}}$: inputs to front-right and front-left servo-valves [A]
$i_{v_{rr}}, i_{v_{rl}}$: inputs to rear-right and rear-left servo-valves [A]

1. Introduction

Performance of a vehicle suspension system is typically rated by its ability to provide improved road handling and improved passenger comfort.

In studies related with an active suspension control system, quarter or half-car models are usually used but full-car models are seldom used. The quarter-car models only deal with vertical motions and cannot reflect pitch, roll and yaw motions in practical car systems. Half-car models (bicycle models) are often considered to perform good handling capabilities (steering control), but they do not include roll motion. Hence to solve this problem, we should consider the full-car model satisfying all the vehicle motions. The full-car model consists of a single sprung mass (car-body) connected to four unsprung masses (front-right, front-left, rear-right and rear-left wheels) at each corner. The model has seven degrees of freedom because the car-body has three degrees of freedom for heave, pitch and roll motions, and each unsprung mass has heave motion.

Some researchers (Jung et al., 2000; Park and Kim, 1998) have been done in controlling pitching and rolling as well as heaving accelerations of the car-body, but they skip the robustness to system parameter variations, and do not consider system including hydraulic actuator. In the paper of Jung et al. (2000), the full-car model is decentralized by two half-car models by overlapping decomposition and each half-car model has each eigenstructure assignment controller, which can move the closed loop eigenvalues to the desired positions. Park et al. (1998) proposed a sliding mode control called decentralized variable structure control. In the active suspension system, the controller can give good performance: small gains from the road disturbances to the heaving, pitching and rolling accelerations of the car-body. Also the controlled system must be robustness to the system parameter variations. In this paper, we applied the H_∞ control theory to full-car model because the H_∞ controller can satisfy the above important problems.

In the early studies, the linear model of suspension is used with the assumption of an ideal force actuator. The most applicable force actuator used in practice is the hydraulic actuator that has high nonlinear characteristics. Hence to solve the complicated problem, in recent studies the dynamics and the nonlinearity of an hydraulic

actuator (Alleyne et al., 1995 ; Fukao et al., 1999 ; Lin et al., 1997) are considered. These papers dealt with the nonlinear dynamics of a hydraulic actuator in a quarter-car model and used these dynamics to formulate a nonlinear control laws, but the control laws were complex. In the hydraulic actuator, there are some unknown factors such as bulk modulus of hydraulic fluid that has strong effects on actuator dynamics. Hence, the nonlinear adaptive control is suitable for designing the actuator controller.

In this paper, the system is divided into two parts : the linear part which is the whole system except the hydraulic actuator, and the nonlinear part which is the hydraulic actuator. The linear part is treated using H_∞ control method that guarantees the robustness of closed-loop system in the presence of uncertainties and minimizes the effects of disturbance. The system parameter variations are taken into account by a multiplicative uncertainty model and the system robustness is guaranteed by small gain theorem. The active system with H_∞ controller can reduces the accelerations of the car body in the heaving, pitching and rolling directions. And the nonlinearity of a hydraulic actuator is treated by nonlinear adaptive control based on back-stepping method (Krstic et al., 1995). The effectiveness of the proposed controllers is verified through simulation results in both time and frequency domains.

2. System Modeling

2.1 Full-car modeling

2.1.1 Full-car model

The configurations of the full-car model is described in Fig. 1. The full-car model consists of a single sprung mass (car body) connected to four unsprung masses (front-right, front-left, rear-right and rear-left wheels) at each corner. The suspensions between the sprung and unsprung masses are modeled as linear viscous dampers and spring elements, while the tires are modeled as simple linear springs without damping.

The model has seven degrees of freedom because the car body has three degrees of freedom

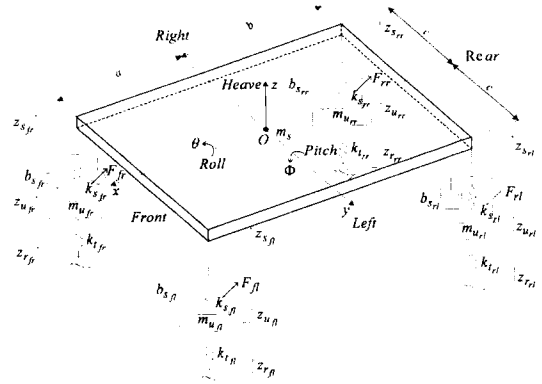

Fig. 1 Configuration of the full-car model

for heave, pitch and roll motions, and each unsprung mass has heave motion.

The following assumptions are made for this model :

- the vehicle center of gravity is located above the pitch and roll centers.
- the pitch and roll angles are small.

2.1.2 State space equation

The dynamic equations of motion for four unsprung masses are given as :

$$m_{u_{fr}} \ddot{z}_{u_{fr}} = b_{s_{fr}} (\dot{z}_{s_{fr}} - \dot{z}_{u_{fr}}) + k_{s_{fr}} (z_{s_{fr}} - z_{u_{fr}}) + k_{t_{fr}} (z_{r_{fr}} - z_{u_{fr}}) - F_{fr} \quad (1)$$

$$m_{u_{fl}} \ddot{z}_{u_{fl}} = b_{s_{fl}} (\dot{z}_{s_{fl}} - \dot{z}_{u_{fl}}) + k_{s_{fl}} (z_{s_{fl}} - z_{u_{fl}}) + k_{t_{fl}} (z_{r_{fl}} - z_{u_{fl}}) - F_{fl} \quad (2)$$

$$m_{u_{rr}} \ddot{z}_{u_{rr}} = b_{s_{rr}} (\dot{z}_{s_{rr}} - \dot{z}_{u_{rr}}) + k_{s_{rr}} (z_{s_{rr}} - z_{u_{rr}}) + k_{t_{rr}} (z_{r_{rr}} - z_{u_{rr}}) - F_{rr} \quad (3)$$

$$m_{u_{rl}} \ddot{z}_{u_{rl}} = b_{s_{rl}} (\dot{z}_{s_{rl}} - \dot{z}_{u_{rl}}) + k_{s_{rl}} (z_{s_{rl}} - z_{u_{rl}}) + k_{t_{rl}} (z_{r_{rl}} - z_{u_{rl}}) - F_{rl} \quad (4)$$

The force balance equation for the car-body is

$$m_s \ddot{z} = b_{s_{fl}} (\dot{z}_{u_{fl}} - \dot{z}_{s_{fl}}) + b_{s_{fr}} (\dot{z}_{u_{fr}} - \dot{z}_{s_{fr}}) + b_{s_{rl}} (\dot{z}_{u_{rl}} - \dot{z}_{s_{rl}}) + b_{s_{rr}} (\dot{z}_{u_{rr}} - \dot{z}_{s_{rr}}) + k_{s_{fr}} (z_{u_{fr}} - z_{s_{fr}}) + k_{s_{fl}} (z_{u_{fl}} - z_{s_{fl}}) + k_{s_{rr}} (z_{u_{rr}} - z_{s_{rr}}) + k_{s_{rl}} (z_{u_{rl}} - z_{s_{rl}}) + F_{fr} + F_{fl} + F_{rr} + F_{rl} \quad (5)$$

The torque balance equations about the rolling axis and the pitching axis are given respectively by

$$\begin{aligned}
I_x \ddot{\theta} = & -cb_{s_{jr}}(\dot{z}_{u_{jr}} - \dot{z}_{s_{jr}}) + cb_{s_{fl}}(\dot{z}_{u_{fl}} - \dot{z}_{s_{fl}}) \\
& -cb_{s_{rr}}(\dot{z}_{u_{rr}} - \dot{z}_{s_{rr}}) + cb_{s_{rl}}(\dot{z}_{u_{rl}} - \dot{z}_{s_{rl}}) \\
& -ck_{s_{jr}}(z_{u_{jr}} - z_{s_{jr}}) + ck_{s_{fl}}(z_{u_{fl}} - z_{s_{fl}}) \\
& -ck_{s_{rr}}(z_{u_{rr}} - z_{s_{rr}}) + ck_{s_{rl}}(z_{u_{rl}} - z_{s_{rl}}) \\
& -cF_{jr} + cF_{fl} - cF_{rr} + cF_{rl}
\end{aligned} \quad (6)$$

$$\begin{aligned}
I_y \ddot{\Phi} = & -ab_{s_{jr}}(\dot{z}_{u_{jr}} - \dot{z}_{s_{jr}}) - ab_{s_{fl}}(\dot{z}_{u_{fl}} - \dot{z}_{s_{fl}}) \\
& + bb_{s_{rr}}(\dot{z}_{u_{rr}} - \dot{z}_{s_{rr}}) + bb_{s_{rl}}(\dot{z}_{u_{rl}} - \dot{z}_{s_{rl}}) \\
& -ak_{s_{jr}}(z_{u_{jr}} - z_{s_{jr}}) - ak_{s_{fl}}(z_{u_{fl}} - z_{s_{fl}}) \\
& + bk_{s_{rr}}(z_{u_{rr}} - z_{s_{rr}}) + bk_{s_{rl}}(z_{u_{rl}} - z_{s_{rl}}) \\
& -aF_{jr} - aF_{fl} + bF_{rr} + bF_{rl}
\end{aligned} \quad (7)$$

We choose the state variables as the following :

- $x_1 = z$: Heaving displacement of the car-body
 $x_2 = \theta$: Pitching angle of the car-body
 $x_3 = \Phi$: Rolling angle of the car-body
 $x_4 = z_{u_{jr}}$: Displacement of front-right unsprung mass
 $x_5 = z_{u_{fl}}$: Displacement of front-left unsprung mass
 $x_6 = z_{u_{rr}}$: Displacement of rear-right unsprung mass
 $x_7 = z_{u_{rl}}$: Displacement of rear-left unsprung mass
 $x_8 = \dot{z}$: Heaving velocity of the car body
 $x_9 = \dot{\theta}$: Pitching angular velocity of the car-body
 $x_{10} = \dot{\Phi}$: Rolling angular velocity of the car-body
 $x_{11} = \dot{z}_{u_{jr}}$: Velocity of front-right unsprung mass
 $x_{12} = \dot{z}_{u_{fl}}$: Velocity of front-left unsprung mass
 $x_{13} = \dot{z}_{u_{rr}}$: Velocity of rear-right unsprung mass
 $x_{14} = \dot{z}_{u_{rl}}$: Velocity of rear-left unsprung mass

Assume that

$$\begin{aligned}
m_{u_{jr}} = m_{u_{fl}} = m_{u_f}; \quad b_{s_{jr}} = b_{s_{fl}} = b_{s_f}; \quad k_{s_{jr}} = k_{s_{fl}} = k_{s_f} \\
m_{u_{rr}} = m_{u_{rl}} = m_{u_r}; \quad b_{s_{rr}} = b_{s_{rl}} = b_{s_r}; \quad k_{s_{rr}} = k_{s_{rl}} = k_{s_r} \\
k_{t_{jr}} = k_{t_{fl}} = k_{t_{rr}} = k_{t_{rl}} = k_t
\end{aligned}$$

The state space equation in matrix form can be given by

$$\dot{x}_p(t) = A_p x_p(t) + B_p u(t) + \Gamma_p d(t) \quad (8)$$

and the measured output equation can be written by

$$y_p(t) = C_p x_p(t) \quad (9)$$

where

$$x_p(t) = [x_1 \ x_2 \ x_3 \ x_4 \ x_5 \ x_6 \ x_7 \ x_8 \ x_9 \ x_{10} \ x_{11} \ x_{12} \ x_{13} \ x_{14}]^T$$

$u(t) = [F_{jr} \ F_{fl} \ F_{rr} \ F_{rl}]^T$: control input

$d(t) = [z_{r_{jr}} \ z_{r_{fl}} \ z_{r_{rr}} \ z_{r_{rl}}]^T$: disturbance

$$A_p = \begin{bmatrix} A_{11} & A_{12} & A_{13} & A_{14} \\ A_{21} & A_{22} & A_{23} & A_{24} \\ A_{31} & A_{32} & A_{33} & A_{34} \end{bmatrix}, \quad B_p = \begin{bmatrix} B_{p11} \\ B_{p21} \\ B_{p31} \end{bmatrix}, \quad \Gamma_p = \begin{bmatrix} \Gamma_1 \\ \Gamma_2 \\ \Gamma_3 \end{bmatrix}$$

with

$$A_1 = [0_{(7 \times 3)}], \quad A_{12} = [0_{(7 \times 4)}]$$

$$A_{13} = [I_{(3 \times 3)}; 0_{(4 \times 3)}], \quad A_{14} = [0_{(3 \times 4)}; I_{(4 \times 4)}]$$

$$A_{21} = \begin{bmatrix} a_{81} & 0 & a_{83} \\ 0 & a_{92} & 0 \\ a_{101} & 0 & a_{103} \end{bmatrix}, \quad A_{21} = \begin{bmatrix} \frac{k_{s_f}}{m_s} & \frac{k_{s_f}}{m_s} & \frac{k_{s_r}}{m_s} & \frac{k_{s_r}}{m_s} \\ -\frac{ck_{s_f}}{I_x} & \frac{ck_{s_f}}{I_x} & -\frac{ck_{s_r}}{I_x} & \frac{ck_{s_r}}{I_x} \\ -\frac{ak_{s_f}}{I_y} & -\frac{ak_{s_f}}{I_y} & \frac{bk_{s_r}}{I_y} & \frac{bk_{s_r}}{I_y} \end{bmatrix}$$

$$A_{23} = \begin{bmatrix} a_{88} & 0 & a_{810} \\ 0 & a_{99} & 0 \\ a_{108} & 0 & a_{1010} \end{bmatrix}, \quad A_{24} = \begin{bmatrix} \frac{b_{s_f}}{m_s} & \frac{b_{s_f}}{m_s} & \frac{b_{s_r}}{m_s} & \frac{b_{s_r}}{m_s} \\ -\frac{cb_{s_f}}{I_x} & \frac{cb_{s_f}}{I_x} & -\frac{cb_{s_r}}{I_x} & \frac{cb_{s_r}}{I_x} \\ -\frac{ab_{s_f}}{I_y} & -\frac{ab_{s_f}}{I_y} & \frac{bb_{s_r}}{I_y} & \frac{bb_{s_r}}{I_y} \end{bmatrix}$$

$$A_{31} = \begin{bmatrix} \frac{k_{s_f}}{m_{u_f}} & -\frac{ck_{s_f}}{m_{u_f}} & -\frac{ak_{s_f}}{m_{u_f}} \\ \frac{k_{s_f}}{m_{u_f}} & \frac{ck_{s_f}}{m_{u_f}} & -\frac{ak_{s_f}}{m_{u_f}} \\ \frac{k_{s_r}}{m_{u_r}} & -\frac{ck_{s_r}}{m_{u_r}} & \frac{bk_{s_r}}{m_{u_r}} \\ \frac{k_{s_r}}{m_{u_r}} & \frac{ck_{s_r}}{m_{u_r}} & \frac{bk_{s_r}}{m_{u_r}} \end{bmatrix}, \quad A_{32} = \begin{bmatrix} a_{114} & 0 & 0 & 0 \\ 0 & a_{125} & 0 & 0 \\ 0 & 0 & a_{134} & 0 \\ 0 & 0 & 0 & a_{147} \end{bmatrix}$$

$$A_{33} = \begin{bmatrix} \frac{b_{s_f}}{m_{u_f}} & -\frac{cb_{s_f}}{m_{u_f}} & -\frac{ab_{s_f}}{m_{u_f}} \\ \frac{b_{s_f}}{m_{u_f}} & \frac{cb_{s_f}}{m_{u_f}} & -\frac{ab_{s_f}}{m_{u_f}} \\ \frac{b_{s_r}}{m_{u_r}} & -\frac{cb_{s_r}}{m_{u_r}} & \frac{bb_{s_r}}{m_{u_r}} \\ \frac{b_{s_r}}{m_{u_r}} & \frac{cb_{s_r}}{m_{u_r}} & \frac{bb_{s_r}}{m_{u_r}} \end{bmatrix}, \quad A_{32} = \begin{bmatrix} -\frac{b_{s_f}}{m_{u_f}} & 0 & 0 & 0 \\ 0 & -\frac{b_{s_f}}{m_{u_f}} & 0 & 0 \\ 0 & 0 & -\frac{b_{s_r}}{m_{u_r}} & 0 \\ 0 & 0 & 0 & -\frac{b_{s_r}}{m_{u_r}} \end{bmatrix}$$

$$B_{p11} = [0_{(7 \times 4)}],$$

$$B_{p21} = \begin{bmatrix} \frac{1}{m_s} & \frac{1}{m_s} & \frac{1}{m_s} & \frac{1}{m_s} \\ -\frac{c}{I_x} & \frac{c}{I_x} & -\frac{c}{I_x} & \frac{c}{I_x} \\ -\frac{a}{I_y} & -\frac{a}{I_y} & \frac{b}{I_y} & \frac{b}{I_y} \end{bmatrix}, \quad A_{32} = \begin{bmatrix} -\frac{1}{m_{u_f}} & 0 & 0 & 0 \\ 0 & \frac{-1}{m_{u_f}} & 0 & 0 \\ 0 & 0 & \frac{-1}{m_{u_r}} & 0 \\ 0 & 0 & 0 & \frac{-1}{m_{u_r}} \end{bmatrix}$$

$$\Gamma_1 = [0_{(7 \times 4)}], \Gamma_2 = [0_{(3 \times 4)}], \Gamma_3 = \begin{bmatrix} \frac{k_t}{m_{uf}} & 0 & 0 & 0 \\ 0 & \frac{k_t}{m_{uf}} & 0 & 0 \\ 0 & 0 & \frac{k_t}{m_{ur}} & 0 \\ 0 & 0 & 0 & \frac{k_t}{m_{ur}} \end{bmatrix}$$

and

$$\begin{aligned} a_{81} &= \frac{-2(k_{s_f} + k_{s_r})}{m_s}, & a_{83} &= \frac{2(ak_{s_f} - bk_{s_r})}{m_s}, \\ a_{88} &= \frac{-2(b_{s_f} + b_{s_r})}{m_s}, & a_{810} &= \frac{-2(ab_{s_f} - bb_{s_r})}{m_s}, \\ a_{92} &= \frac{-2c^2(k_{s_f} + k_{s_r})}{I_x}, & a_{99} &= \frac{-2c^2(b_{s_f} + b_{s_r})}{I_x}, \\ a_{101} &= \frac{2(ak_{s_f} - bk_{s_r})}{I_y}, & a_{103} &= \frac{2(a^2k_{s_f} + b^2k_{s_r})}{I_y}, \\ a_{108} &= \frac{2(ab_{s_f} - bb_{s_r})}{I_y}, & a_{1010} &= \frac{-2(a_2b_{s_f} + b^2b_{s_r})}{I_y}, \\ a_{114} &= \frac{-(k_{s_f} + k_t)}{m_{u_f}}, & a_{125} &= \frac{-(k_{s_f} + k_t)}{m_u}, \\ a_{136} &= \frac{-(k_{s_r} + k_t)}{m_{u_r}}, & a_{147} &= \frac{-(k_{s_r} + k_t)}{m_{u_r}}. \end{aligned}$$

2.2 Hydraulic actuator modeling

2.2.1 Hydraulic actuator model and dynamic equations

It is assumed that the hydraulic actuator consists of a spool valve and a hydraulic cylinder. P_s and P_r are the pressures of the hydraulic fluid supplied from and returned to the spool valve, respectively. As the spool valve moves upward (positive z_v), the upper chamber of the cylinder is connected to the supply line and its pressure increases. In the meantime, the lower chamber is

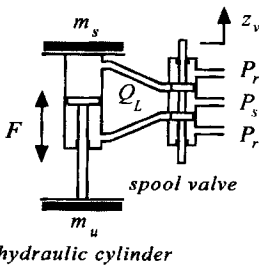

Fig. 2 Configuration of hydraulic actuator

connected to the return line and its pressure decreases. The dynamic equation of the hydraulic actuator is given as (Merritt, 1967):

$$\frac{V_t}{4\beta_e} \dot{P}_L = Q_L - C_{tm}P_L - A(\dot{Z}_s - \dot{Z}_u) \tag{10}$$

where $Q_L = C_d w z_v \sqrt{\frac{P_s - \text{sgn}(z_v) P_L}{\rho}}$ (11)

The relationship between the spool valve displacement z_v and the pressure across the load P_L can be expressed

$$\begin{aligned} \dot{P}_L &= -\frac{4\beta_e}{V_t} C_{tm}P_L - \frac{4\beta_e}{V_t} A(\dot{Z}_s - \dot{Z}_u) \\ &\quad + \frac{4\beta_e}{V_t} C_d w z_v \sqrt{\frac{P_s - \text{sgn}(z_v) P_L}{\rho}} \end{aligned} \tag{12}$$

or $\dot{P}_L = -\beta P_L - \alpha A(\dot{Z}_s - \dot{Z}_u) + \gamma \sqrt{P_s - \text{sgn}(z_v) P_L} z_v$ (13)

where $\alpha \equiv \frac{4\beta_e}{V_t}$, $\beta \equiv \alpha C_{tm}$, $\gamma \equiv \alpha C_d w \sqrt{\frac{1}{\rho}}$

By multiplying (13) by A , we can get the relationship between the spool valve displacement z_v and the generated force F

$$\begin{aligned} \dot{F} &= -\beta F - \alpha A^2(\dot{Z}_s - \dot{Z}_u) \\ &\quad + \gamma \sqrt{A \sqrt{P_s A - \text{sgn}(z_v) F}} z_v \end{aligned} \tag{14}$$

The valve displacement z_v is related to the input of servo-valve i_v as follows:

$$\dot{z}_v = \frac{1}{\tau} (-z_v + i_v) \tag{15}$$

We have the following relationships

$$\dot{z}_{s_{fr}} - \dot{z}_{u_{fr}} = x_8 - cx_9 - ax_{10} - x_{11} \tag{16}$$

$$\dot{z}_{s_{fl}} - \dot{z}_{u_{fl}} = x_8 + cx_9 - ax_{10} - x_{12} \tag{17}$$

$$\dot{z}_{s_{rr}} - \dot{z}_{u_{rr}} = x_8 - cx_9 + bx_{10} - x_{13} \tag{18}$$

$$\dot{z}_{s_{rl}} - \dot{z}_{u_{rl}} = x_8 + cx_9 + bx_{10} - x_{14} \tag{19}$$

Because the full-car model has x -symmetric axis, the front-right and front-left hydraulic actuators have the same specifications and rear-right and rear-left ones also have the same specifications.

2.2.2 Dynamic equations of four hydraulic actuators in full-car model

Based on (14) and (15), the dynamic equations of four hydraulic actuators in full-car model can be expressed as follows:

$$\dot{F}_{fr} = -\beta_f F_{fr} - \alpha_f A_f^2 (x_8 - cx_9 - ax_{10} - x_{11}) + \gamma_f \sqrt{A_f} \sqrt{P_{s_f} A_f - \text{sgn}(z_{v_{fr}}) F_{fr} z_{v_{fr}}} \quad (20)$$

$$\dot{z}_{v_{fr}} = \frac{1}{\tau_f} (-z_{v_{fr}} + i_{v_{fr}}) \quad (21)$$

$$\dot{F}_{fl} = -\beta_f F_{fl} - \alpha_f A_f^2 (x_8 + cx_9 - ax_{10} - x_{12}) + \gamma_f \sqrt{A_f} \sqrt{P_{s_f} A_f - \text{sgn}(z_{v_{fl}}) F_{fl} z_{v_{fl}}} \quad (22)$$

$$\dot{z}_{v_{fl}} = \frac{1}{\tau_f} (-z_{v_{fl}} + i_{v_{fl}}) \quad (23)$$

$$\dot{F}_{rr} = -\beta_r F_{rr} - \alpha_r A_r^2 (x_8 - cx_9 + bx_{10} - x_{13}) + \gamma_r \sqrt{A_r} \sqrt{P_{s_r} A_r - \text{sgn}(z_{v_{rr}}) F_{rr} z_{v_{rr}}} \quad (24)$$

$$\dot{z}_{v_{rr}} = \frac{1}{\tau_r} (-z_{v_{rr}} + i_{v_{rr}}) \quad (25)$$

$$\dot{F}_{rl} = -\beta_r F_{rl} - \alpha_r A_r^2 (x_8 + cx_9 + bx_{10} - x_{14}) + \gamma_r \sqrt{A_r} \sqrt{P_{s_r} A_r - \text{sgn}(z_{v_{rl}}) F_{rl} z_{v_{rl}}} \quad (26)$$

$$\dot{z}_{v_{rl}} = \frac{1}{\tau_r} (-z_{v_{rl}} + i_{v_{rl}}) \quad (27)$$

3. H_∞ Design of the Linear Part

3.1 Preliminaries for H_∞ controller design

The scheme of the proposed controller can be seen from Fig. 3, where :

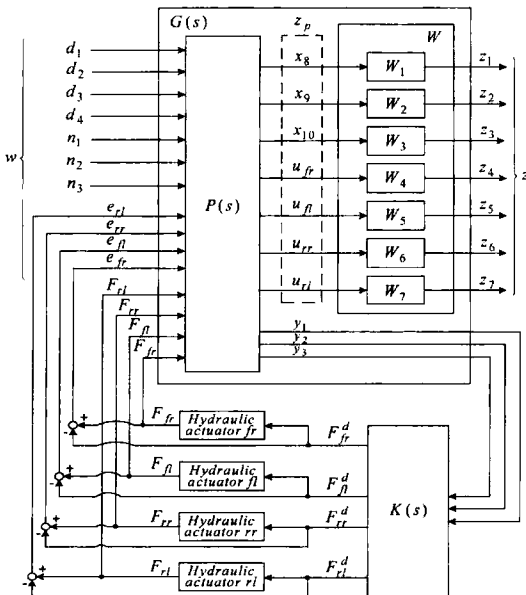

Fig. 3 The proposed controller

$P(s)$: Plant (full-car suspension system)

$W(s)$: Weighting functions

$G(s)$: Augmented system

$K(s)$: H_∞ controller

n_1, n_2, n_3 : Measurement noises

Let's define the force errors :

$$e_{fr} = F_{fr} - F_{fr}^d ; e_{fl} = F_{fl} - F_{fl}^d ; e_{rr} = F_{rr} - F_{rr}^d ; e_{rl} = F_{rl} - F_{rl}^d ;$$

where $F_{fr}, F_{fl}, F_{rr}, F_{rl}$ are actual forces generated from the front-right, front-left, rear-right and rear-left hydraulic actuators, respectively.

And $F_{fr}^d, F_{fl}^d, F_{rr}^d, F_{rl}^d$ are those desired forces calculated from H_∞ controller.

The above errors are considered as the disturbances for the linear system.

Let us consider that $u = [F_{fr} \ F_{fl} \ F_{rr} \ F_{rl}]^T$ is defined as the control input for the force generated at the front-right, front-left, rear-right and rear-left suspensions respectively, then the systems (8)-(9) can be rewritten in the form :

$$\dot{x}_p = A_p x_p + B_p u + G_p \begin{bmatrix} d \\ e \end{bmatrix} \quad (28)$$

$$y_p = C_p x_p \quad (29)$$

where $d = [z_{rfr} \ z_{rfl} \ z_{rrr} \ z_{rrl}]^T, e = [e_{fr} \ e_{fl} \ e_{rr} \ e_{rl}]^T$.

The considered transfer functions of interest are these from disturbance to the heaving acceleration, pitching acceleration and rolling acceleration of the car body.

The state space representation of the plant can be written in the form :

$$\dot{x}_p = A_p x_p + B_{p1} w + B_{p2} u \quad (30)$$

$$z_p = C_{p1} x_p + D_{p11} w + D_{p12} u \quad (31)$$

$$y_p = C_{p2} x_p + D_{p21} w + D_{p22} u \quad (32)$$

where

$$B_{p1} = [G_p \ 0_{(14 \times 3)}], \ B_{p2} = B_p,$$

$$C_{p1} = [C_{p11} \ C_{p12} \ C_{p13} \ C_{p14} \ C_{p15} \ C_{p16} \ C_{p17}],$$

$$C_{p2} = C_p,$$

$$D_{p11} = [D_{p111} \ D_{p112} \ D_{p113} \ D_{p114} \ D_{p115} \ D_{p116} \ D_{p117}],$$

$$D_{p12} = [D_{p121} \ D_{p122} \ D_{p123} \ D_{p124} \ D_{p125} \ D_{p126} \ D_{p127}],$$

$$D_{p21} = [0_{(3 \times 4)} \ I_{(3 \times 3)} \ 0_{(3 \times 4)}],$$

$$D_{p22} = [0_{(3 \times 4)}].$$

From Eq. (21), the controlled output z_p can be partitioned as follows :

$$z_p = \begin{bmatrix} x_8 \\ x_9 \\ x_{10} \\ u_1 \\ u_2 \\ u_3 \\ u_4 \end{bmatrix} = \begin{bmatrix} C_{p11} \\ C_{p12} \\ C_{p13} \\ C_{p14} \\ C_{p15} \\ C_{p16} \\ C_{p17} \end{bmatrix} x_p + \begin{bmatrix} C_{p111} \\ C_{p112} \\ C_{p113} \\ C_{p114} \\ C_{p115} \\ C_{p116} \\ C_{p117} \end{bmatrix} w + \begin{bmatrix} C_{p121} \\ C_{p122} \\ C_{p123} \\ C_{p124} \\ C_{p125} \\ C_{p126} \\ C_{p127} \end{bmatrix} u \quad (33)$$

Assume that the weighting functions W_1, W_2, W_3 corresponding to the states x_8, x_9, x_{10} have dynamic equations :

$$\dot{x}_{w_1} = A_{w_1}x_{w_1} + B_{w_1}x_8 \quad (34)$$

$$z_1 = C_{w_1}x_{w_1} + D_{w_1}x_8 \quad (35)$$

$$\dot{x}_{w_2} = A_{w_2}x_{w_2} + B_{w_2}x_9 \quad (36)$$

$$z_2 = C_{w_2}x_{w_2} + D_{w_2}x_9 \quad (37)$$

$$\dot{x}_{w_3} = A_{w_3}x_{w_3} + B_{w_3}x_{10} \quad (38)$$

$$z_3 = C_{w_3}x_{w_3} + D_{w_3}x_{10} \quad (39)$$

The weights W_4, W_5, W_6, W_7 corresponding to the active forces u_1, u_2, u_3, u_4 are scalar values $W_4 = \alpha_1, W_5 = \alpha_2, W_6 = \alpha_3, W_7 = \alpha_4$, respectively.

From Eq. (33), we have :

$$x_8 = C_{p11}x_p + D_{p111}w + D_{p121}u \quad (40)$$

$$x_9 = C_{p12}x_p + D_{p112}w + D_{p122}u \quad (41)$$

$$x_{10} = C_{p13}x_p + D_{p113}w + D_{p123}u \quad (42)$$

Substituting Eq. (40) into Eqs. (34) and (35), we obtain :

$$\begin{aligned} \dot{x}_{w_1} &= A_{w_1}x_{w_1} + B_{w_1}(C_{p11}x_p + D_{p111}w + D_{p121}u) \\ &= B_{w_1}C_{p11}x_p + A_{w_1}x_{w_1} + B_{w_1}D_{p111}w + B_{w_1}D_{p121}u \end{aligned} \quad (43)$$

$$\begin{aligned} z_1 &= C_{w_1}x_{w_1} + D_{w_1}(C_{p11}x_p + D_{p111}w + D_{p121}u) \\ &= D_{w_1}C_{p11}x_p + C_{w_1}x_{w_1} + D_{w_1}D_{p111}w + D_{w_1}D_{p121}u \end{aligned} \quad (44)$$

Substituting Eq. (41) into Eqs. (36) and (37),

$$\begin{aligned} \dot{x}_{w_2} &= A_{w_2}x_{w_2} + B_{w_2}(C_{p12}x_p + D_{p112}w + D_{p122}u) \\ &= B_{w_2}C_{p12}x_p + A_{w_2}x_{w_2} + B_{w_2}D_{p112}w + B_{w_2}D_{p122}u \end{aligned} \quad (45)$$

$$\begin{aligned} z_2 &= C_{w_2}x_{w_2} + D_{w_2}(C_{p12}x_p + D_{p112}w + D_{p122}u) \\ &= D_{w_2}C_{p12}x_p + C_{w_2}x_{w_2} + D_{w_2}D_{p112}w + D_{w_2}D_{p122}u \end{aligned} \quad (46)$$

Substituting Eq. (42) into Eqs. (38) and (39),

$$\begin{aligned} \dot{x}_{w_3} &= A_{w_3}x_{w_3} + B_{w_3}(C_{p13}x_p + D_{p113}w + D_{p123}u) \\ &= B_{w_3}C_{p13}x_p + A_{w_3}x_{w_3} + B_{w_3}D_{p113}w + B_{w_3}D_{p123}u \end{aligned} \quad (47)$$

$$\begin{aligned} z_3 &= C_{w_3}x_{w_3} + D_{w_3}(C_{p13}x_p + D_{p113}w + D_{p123}u) \\ &= D_{w_3}C_{p13}x_p + C_{w_3}x_{w_3} + D_{w_3}D_{p113}w + D_{w_3}D_{p123}u \end{aligned} \quad (48)$$

From Eq. (33), we have

$$\begin{cases} u_1 = C_{p14}x_p + D_{p114}w + D_{p124}u \\ z_4 = \alpha_1 u_1 \end{cases} \quad (49)$$

$$\begin{cases} u_2 = C_{p15}x_p + D_{p115}w + D_{p125}u \\ z_5 = \alpha_2 u_2 \end{cases} \quad (50)$$

$$\begin{cases} u_3 = C_{p16}x_p + D_{p116}w + D_{p126}u \\ z_6 = \alpha_3 u_3 \end{cases} \quad (51)$$

$$\begin{cases} u_4 = C_{p17}x_p + D_{p117}w + D_{p127}u \\ z_7 = \alpha_4 u_4 \end{cases} \quad (52)$$

From Eqs. (30), (43), (45) and (47)

$$\begin{aligned} \begin{bmatrix} \dot{x}_p \\ \dot{x}_{w_1} \\ \dot{x}_{w_2} \\ \dot{x}_{w_3} \end{bmatrix} &= \begin{bmatrix} A_p & 0_{(14 \times 3)} \\ B_{w_1}C_{p11} & A_{w_1} & 0 & 0 \\ B_{w_2}C_{p12} & 0 & A_{w_2} & 0 \\ B_{w_3}C_{p13} & 0 & 0 & A_{w_3} \end{bmatrix} \begin{bmatrix} x_p \\ x_{w_1} \\ x_{w_2} \\ x_{w_3} \end{bmatrix} \\ &+ \begin{bmatrix} B_{p1} \\ B_{w_1}D_{p111} \\ B_{w_2}D_{p112} \\ B_{w_3}D_{p113} \end{bmatrix} w + \begin{bmatrix} B_{p2} \\ B_{w_1}D_{p121} \\ B_{w_2}D_{p122} \\ B_{w_3}D_{p123} \end{bmatrix} u \end{aligned} \quad (53)$$

From Eqs. (44), (46), (48), (49), (50), (51) and (52)

$$\begin{aligned} \begin{bmatrix} z_1 \\ z_2 \\ z_3 \\ z_4 \\ z_5 \\ z_6 \\ z_7 \end{bmatrix} &= \begin{bmatrix} D_{w_1}C_{p11} & C_{w_1} & 0 & 0 \\ D_{w_2}C_{p12} & 0 & C_{w_2} & 0 \\ D_{w_3}C_{p13} & 0 & 0 & C_{w_3} \\ \alpha_1 C_{p14} & 0 & 0 & 0 \\ \alpha_2 C_{p15} & 0 & 0 & 0 \\ \alpha_3 C_{p16} & 0 & 0 & 0 \\ \alpha_4 C_{p17} & 0 & 0 & 0 \end{bmatrix} \begin{bmatrix} x_p \\ x_{w_1} \\ x_{w_2} \\ x_{w_3} \end{bmatrix} \\ &+ \begin{bmatrix} D_{w_1}D_{p111} \\ D_{w_2}D_{p112} \\ D_{w_3}D_{p113} \\ \alpha_1 D_{p114} \\ \alpha_2 D_{p115} \\ \alpha_3 D_{p116} \\ \alpha_4 D_{p117} \end{bmatrix} w + \begin{bmatrix} D_{w_1}D_{p121} \\ D_{w_2}D_{p122} \\ D_{w_3}D_{p123} \\ \alpha_1 D_{p124} \\ \alpha_2 D_{p125} \\ \alpha_3 D_{p126} \\ \alpha_4 D_{p127} \end{bmatrix} u \end{aligned} \quad (54)$$

Eq. (32) can be rewritten as follows :

$$y = \begin{bmatrix} C_{p2} & 0_{(3 \times 3)} \\ & \begin{bmatrix} x_p \\ x_{w_1} \\ x_{w_2} \\ x_{w_3} \end{bmatrix} \end{bmatrix} + \begin{bmatrix} 0_{(3 \times 4)} & I_{(3 \times 3)} & 0_{(3 \times 4)} \end{bmatrix} \begin{bmatrix} d \\ n \\ e \end{bmatrix} + \begin{bmatrix} 0_{3 \times 4} \end{bmatrix} u \quad (55)$$

Rearranging Eqs. (53)-(55) yields :

$$\dot{x} = Ax + B_1 w + B_2 u \quad (56)$$

$$z = C_1 x + D_{11} w + D_{12} u \quad (57)$$

$$y = C_2 x + D_{21} w + D_{22} u \quad (58)$$

where $x = [x_p \ x_{w_1} \ x_{w_2} \ x_{w_3}]^T$,

$$z = [z_1 \ z_2 \ z_3 \ z_4 \ z_5 \ z_6 \ z_7]^T,$$

$$y = [x_8 \ x_9 \ x_{10}]^T$$

$$A = \begin{bmatrix} A_p & 0_{(14 \times 3)} \\ B_{w_1} C_{p_{11}} & A_{w_1} & 0 & 0 \\ B_{w_2} C_{p_{12}} & 0 & A_{w_2} & 0 \\ B_{w_3} C_{p_{13}} & 0 & 0 & A_{w_3} \end{bmatrix}, B_1 = \begin{bmatrix} B_{p_1} \\ B_{w_1} D_{p_{111}} \\ B_{w_2} D_{p_{112}} \\ B_{w_3} D_{p_{113}} \end{bmatrix}, B_2 = \begin{bmatrix} B_{p_2} \\ B_{w_1} D_{p_{121}} \\ B_{w_2} D_{p_{122}} \\ B_{w_3} D_{p_{123}} \end{bmatrix}$$

$$C_1 = \begin{bmatrix} D_{w_1} C_{p_{11}} & C_{w_1} & 0 & 0 \\ D_{w_2} C_{p_{12}} & 0 & C_{w_2} & 0 \\ D_{w_3} C_{p_{13}} & 0 & 0 & C_{w_3} \\ \alpha_1 C_{p_{14}} & 0 & 0 & 0 \\ \alpha_2 C_{p_{15}} & 0 & 0 & 0 \\ \alpha_3 C_{p_{16}} & 0 & 0 & 0 \\ \alpha_4 C_{p_{17}} & 0 & 0 & 0 \end{bmatrix}, D_{11} = \begin{bmatrix} D_{w_1} D_{p_{111}} \\ D_{w_2} D_{p_{112}} \\ D_{w_3} D_{p_{113}} \\ \alpha_1 D_{p_{114}} \\ \alpha_2 D_{p_{115}} \\ \alpha_3 D_{p_{116}} \\ \alpha_4 D_{p_{117}} \end{bmatrix}, D_{12} = \begin{bmatrix} D_{w_1} D_{p_{121}} \\ D_{w_2} D_{p_{122}} \\ D_{w_3} D_{p_{123}} \\ \alpha_1 D_{p_{124}} \\ \alpha_2 D_{p_{125}} \\ \alpha_3 D_{p_{126}} \\ \alpha_4 D_{p_{127}} \end{bmatrix}$$

$$C_2 = [C_{p_2} \ 0_{(3 \times 3)}], D_{21} = [0_{(3 \times 4)} \ I_{(3 \times 3)} \ 0_{(3 \times 4)}], D_{22} = [0_{(3 \times 4)}].$$

The augmented system $G(s)$ is fitted to the standard form of the H_∞ control problem. Now we will use H_∞ theory to find a controller $K(s)$ satisfying the above stated control objectives.

3.2 H_∞ formulation and solution

The H_∞ control problem is to find a controller $K(s)$ for the augmented system $G(s)$ such that the ∞ -norm of the closed loop transfer function T_{zw} is below a given positive scalar γ (Doyle et al., 1989):

$$\text{Find } K(s) : \|T_{zw}\|_\infty \leq \gamma \quad (59)$$

For the problem to have a solution, the following conditions must be satisfied (Doyle et al., 1989):

- i. (A, B_2) is stabilizable, and (C_2, A) is detectable
- ii. D_{12} is full column rank, and D_{21} is full row rank
- iii. $\begin{bmatrix} A - j\omega I & B_2 \\ C_1 & D_{12} \end{bmatrix}$ has full column rank for all ω
- iv. $\begin{bmatrix} A - j\omega I & B_1 \\ C_2 & D_{21} \end{bmatrix}$ has full row rank for all ω
- v. $D_{11} = 0$ and $D_{22} = 0$

The H_∞ solution involves two Hamilton matrices

$$H_\infty = \begin{bmatrix} A & \gamma^{-2} B_1 B_1^T - B_2 B_2^T \\ -C_1^T C_1 & -A^T \end{bmatrix}$$

$$\text{and } J_\infty = \begin{bmatrix} A^T & \gamma^{-2} C_1^T C_1 - C_2^T C_2 \\ -B_1 B_1^T & -A \end{bmatrix}$$

There exists an admissible controller such that $\|T_{zw}\|_\infty \leq \gamma$ iff the following three conditions hold (Doyle et al., 1989):

1. $H_\infty \in \text{dom}(\text{Ric})$ and $X_\infty := \text{Ric}(H_\infty) \geq 0$
2. $J_\infty \in \text{dom}(\text{Ric})$ and $Y_\infty := \text{Ric}(J_\infty) \geq 0$
3. $\rho(X_\infty, Y_\infty) < \gamma^2$ ($\rho(A)$: spectral radius of $A =$ largest eigenvalues of A)

When these conditions hold, one such controller is

$$K(s) = \begin{bmatrix} A_K & B_K \\ C_K & D_K \end{bmatrix} = \begin{bmatrix} \hat{A}_\infty & -Z_\infty L_\infty \\ F_\infty & 0 \end{bmatrix} \quad (60)$$

where

$$\begin{aligned} \hat{A}_\infty &= A + \gamma^{-2} B_1 B_1^T X_\infty + B_2 F_\infty + Z_\infty L_\infty C_2 \\ F_\infty &= -B_2^T X_\infty \\ L_\infty &= -Y_\infty C_2^T \\ Z_\infty &= (I - \gamma^{-2} Y_\infty X_\infty)^{-1} \end{aligned}$$

3.3 Uncertainty description and choosing weighting functions

The change of parameters is assumed as follows:

1. the change of sprung mass (car body mass) includes passengers and luggage weights: Δ_{ms}
2. when the damping coefficients are measured, these errors are about $\pm 10\%$ of the given values.

Assume that $\Delta_{ms} = 500$ kg, $\Delta_{b_{sf}} = \pm 10\% b_{sf}$ and $\Delta_{b_{sr}} = \pm 10\% b_{sr}$.

From the small gain theorem, the robustness of the closed-loop system in the presence of uncertainties is assured if $\gamma < 1$. The change in the parameters of the system is taken into account by multiplicative uncertainty model and the uncertainty $\Delta(s)$ is derived from the nominal plant $P_n(s)$ and the perturbed plant $P_p(s)$ as follows (Shahian and Hassul, 1993):

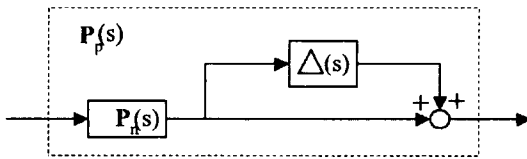

Fig. 4 Multiplicative uncertainty at the plant output

$$\Delta(s) = \frac{P_p(s) - P_n(s)}{P_n(s)} \tag{61}$$

The weighting functions are chosen so as to satisfy

$$|\Delta(j\omega)| < |W(j\omega)|, \forall \omega \tag{62}$$

Our problem can be solved if γ satisfying the conditions in section 3.2 with the weighting functions are chosen so as to satisfy condition (62) and $\gamma < 1$.

4. Adaptive Nonlinear Design of the Actuator Part

4.1 Preliminaries for adaptive nonlinear controller design

We consider the hydraulic actuator dynamic Eqs. (20) and (21). Two parameters are considered as unknown parameters: $\alpha_{f_j} = 4\beta_{e_{f_j}}/V_{t_j}$ and $1/\tau_{f_j}$. The main reason for choosing α_{f_j} as an unknown factor is that the bulk modulus of hydraulic fluid is known to change dramatically even when there is a small leakage between a piston and a cylinder. The next parameter is the time constant and is known to affect the control performance greatly.

Equations (20) and (21) can be written in the form

$$\dot{F}_{f_r} = \theta_1 [a_1 F_{f_r} + a_2(x_8 - cx_9 - ax_{10} - x_{11}) + a_3\sqrt{P_{s_f}A_f - \text{sgn}(z_{v_{f_r}})F_{f_r}z_{v_{f_r}}}] \tag{63}$$

$$\dot{z}_{v_{f_r}} = \theta_2(-z_{v_{f_r}} + i_{f_r}) \tag{64}$$

where θ_1, θ_2 are unknown parameters

$$a_1 = -C_{tm_{f_j}}, a_2 = -A_f^2, a_3 = C_{d_f}\omega_{f_j}\sqrt{A_f/\rho_f}$$

Our purpose is to design a controller such that F_{f_r} can track its desired value $F_{f_r}^d$ by using adaptive non-linear control based on the back-stepping method (Krstic et al., 1995).

4.2 Adaptive nonlinear control via back-stepping method

The back-stepping method can be stated as follows :

[1] The 1st step :

Consider Eq. (64) with virtual control $z_{v_{f_r}}$ and rewrite it in the form :

$$\dot{F}_{f_r} = \theta_1 [\varphi_1 + a_3\sqrt{P_{s_f}A_f - \text{sgn}(z_{v_{f_r}})F_{f_r}z_{v_{f_r}}}] \tag{65}$$

$$\text{where } \varphi_1 = a_1a_{15} + a_2(x_8 - cx_9 - ax_{10} - x_{11}) \tag{66}$$

We define the first error variable

$$e_1 \equiv F_{f_r} - F_{f_r}^d \quad (e_1 = e_{f_r}) \tag{67}$$

Its first derivative is obtained

$$\dot{e}_1 = \theta_1\varphi_1 + \theta_1a_3\sqrt{P_{s_f}A_f - \text{sgn}(z_{v_{f_r}})F_{f_r}z_{v_{f_r}}} - \dot{F}_{f_r}^d \tag{68}$$

Let θ_1 be estimated by $\hat{\theta}_1$. If the virtual $z_{v_{f_r}}$ control is chosen to satisfy $\theta_1z_{v_{f_r}} = \hat{\theta}_1\alpha_1$, where

$$\alpha_1 = \frac{-c_{f_1}e_1 - \hat{\theta}_1\varphi_1 + \dot{F}_{f_r}^d}{\hat{\theta}_1a_3\sqrt{P_{s_f}A_f - \text{sgn}(z_{v_{f_r}})F_{f_r}z_{v_{f_r}}}} \tag{69}$$

then Eq. (68) becomes

$$\dot{e}_1 = -c_{f_1}e_1 + \tilde{\theta}_1\varphi_1 \tag{70}$$

where $\tilde{\theta} = \theta_1 - \hat{\theta}_1$ is the error of parameter estimation.

Next we choose the Lyapunov function as

$$V_1 = \frac{1}{2}e_1^2 + \frac{1}{2\gamma_{f_1}}\tilde{\theta}_1^2 \geq 0 \tag{71}$$

$$\text{then } \dot{V}_1 = -c_{f_1}e_1^2 - \frac{1}{\gamma_{f_1}}\tilde{\theta}_1(\dot{\tilde{\theta}}_1 - \gamma_{f_1}\varphi_1e_1) \tag{72}$$

$\dot{V}_1 \leq 0$ when we eliminate $\tilde{\theta}_1$ with the update law:

$$\dot{\hat{\theta}}_1 - \gamma_{f_1}\varphi_1e_1 \tag{73}$$

where $\gamma_{f_1} > 0$ is the adaptation gain.

[2] The 2nd step :

We define the second error variable

$$e_2 \equiv z_{v_{f_r}} - \alpha_1 \tag{74}$$

Its first derivative can be given as

$$\dot{e}_2 = -\theta_2z_{v_{f_r}} + \theta_2i_{f_r} - \dot{\alpha}_1 \tag{75}$$

The Lyapunov function is chosen as

$$V_2 = \frac{1}{2} e_2^2 + \frac{1}{2\gamma_{f_2}} \tilde{\theta}_2^2 \geq 0 \tag{76}$$

The first derivative of V_2 is

$$\dot{V}_2 = -c_{f_2} e_2^2 - \frac{1}{\gamma_{f_2}} \tilde{\theta}_2 (\dot{\tilde{\theta}}_2 + \gamma_{f_2} (e_2 + \alpha_1) e_2) \tag{77}$$

The control law i_{fr} and update law for $\hat{\theta}_2$ are given as follows :

$$i_{fr} = \frac{-c_{f_2} e_2 + \hat{\theta}_2 (e_2 + \alpha_1) + \dot{\alpha}_1}{\hat{\theta}_2} \tag{78}$$

$$\dot{\hat{\theta}}_2 = -\gamma_{f_2} (e_2 + \alpha_1) e_2 \tag{79}$$

where $\gamma_{f_2} > 0$ is the adaptation gain.

Similarly, we apply the above procedure to the pairs of Eqs. (22)-(23), (24)-(25), and (26)-(27).

5. Simulation Results

The numerical values used in this simulation are referred to the work of Park and Kim (1998) and Alleyne and Hedrick (1995), and are given in Table 1 and Table 2.

Table 1 Numerical values of full-car model for simulation

Parameters	Values	Units
sprung mass	m_s	1460 kg
front unsprung mass	m_f	40 kg
rear unsprung mass	m_r	35.5 kg
front damping coefficient	b_{s_f}	1290 N·s/m
rear damping coefficient	k_{s_r}	1620 N·s/m
front spring coefficient	k_{s_f}	19960 N/m
rear spring coefficient	k_{s_r}	17500 N/m
tire stiffness coefficient	k_t	175500 N/m
rolling moment of inertia of the car-body	I_x	460 kg·m ²
pitching moment of inertia of the car-body	I_y	2460 kg·m ²
distance between the center of gravity of car-body and front axle	a	1.011 m
distance between the center of gravity of car-body and rear axle	b	1.803 m
half of width of car-body	c	0.755 m

The weighting functions and the value of γ are chosen as

$$W_1 = \frac{15s+0.1}{45s+150}; \quad W_2 = \frac{18s+0.1}{159s+1350}; \quad W_3 = \frac{22s+0.1}{67s+185};$$

$$W_4 = 3.5 \times 10^{-6}; \quad W_5 = 3.5 \times 10^{-6}; \quad W_6 = 4.3 \times 10^{-3};$$

$$W_7 = 4.3 \times 10^{-3}; \quad \gamma = 0.9986$$

The gains of adaptive controllers are chosen as

$$\gamma_{f_1} = \gamma_{f_2} = 10^6; \quad c_{f_1} = 6500; \quad c_{f_2} = 10;$$

$$\gamma_{r_1} = \gamma_{r_2} = 10^6; \quad c_{r_1} = 7000; \quad c_{r_2} = 5$$

The input disturbances at the rear wheels z_{rrr} and $z_{rrl}(t)$ are relatively identical to the input disturbances at the front wheels $z_{rrr}(t)$ and $z_{rll}(t)$, except for a time delay.

$$z_{rrr}(t) = A_{f_r} \sin(\omega t); \quad z_{rrr}(t) = A_{rr} \sin[\omega(t+\tau)];$$

$$z_{rll}(t) = A_{f_l} \sin(\omega t); \quad z_{rll}(t) = A_{rl} \sin[\omega(t+\tau)].$$

where

ω : disturbance frequency.

$A_{f_r}, A_{f_l}, A_{rr}, A_{rl}$: disturbances amplitudes at the front-right, front-left, rear-right and rear-left wheels respectively.

τ : time delay, $\tau = \frac{a+b}{v}$ with is the car's velocity.

5.1 Frequency domain

The plots of uncertainties and weighting functions are given in Figs. 5, 6 and 7. Figs. 8-10 show the gain plots of the transfer functions from disturbance to the heaving, pitching and rolling accelerations of the car-body in three cases : pas-

Table 2 Numerical values of hydraulic actuators for simulation

Parameters	Values	Units
α_{f_l}	4.515e13	N/m ⁵
β_f	1.00	
γ_f	1.545e9	N/(m ^{5/2} kg ^{1/2})
A_f	3.35e-4	m ²
P_{s_f}	10342500	N/m ²
α_{f_r}	5.145e13	N/m ⁵
β_r	1.00	
γ_r	1.835e9	N/(m ^{5/2} kg ^{1/2})
A_r	2.85e-4	m ²
P_{s_r}	9545000	N/m ²

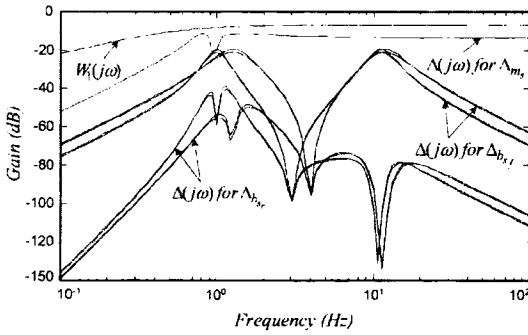

Fig. 5 Plots of uncertainties and weighting function W_1

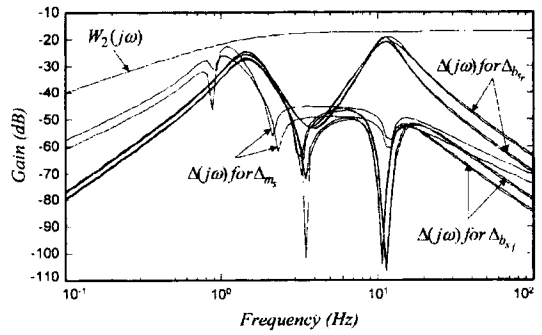

Fig. 6 Plots of uncertainties and weighting function W_2

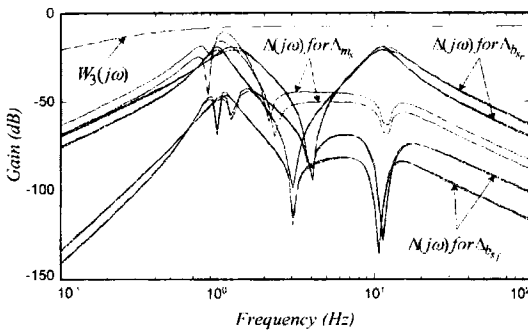

Fig. 7 Plots of uncertainties and weighting function W_3

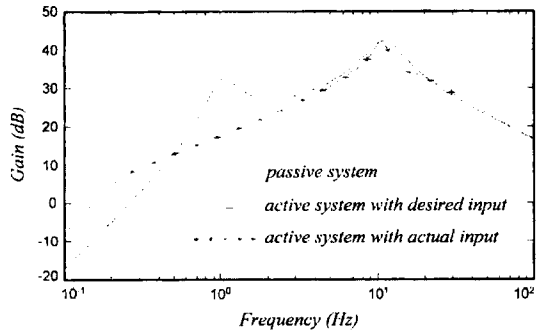

Fig. 8 Gain plot of heaving acceleration of the car-body

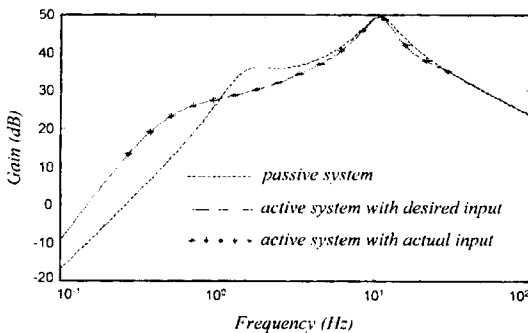

Fig. 9 Gain plot of pitching acceleration of the car-body

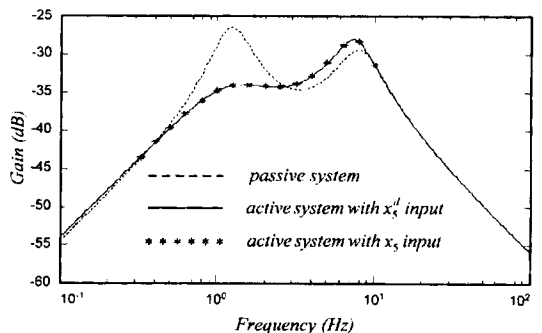

Fig. 10 Gain plot of rolling acceleration of the car-body

sive system, active system with desired input and active system with actual input.

A human is very sensitive to the vertical vibrations that occur over the frequency range of 1-2 Hz, to the pitch vibrations over the range of 1.3-2.5 Hz, and to the roll vibrations over the range of 1.5-2 Hz, and less sensitive to the frequencies outside these ranges (Gillespie, 1992).

In Fig. 8, although the heaving acceleration is somewhat higher in the active case than in the passive case below 0.5 Hz, but the active suspension improves at 0.5-2 Hz, which is the sensitive frequency region of a human in heaving vibration. Also, we can see in Fig. 9 and Fig. 10, the active system greatly improves the pitching and rolling accelerations at the sensitive frequency

regions of a human.

The above figures show that adaptive nonlinear control could cope with the nonlinearity of the hydraulic actuator, and the frequency properties set by H_∞ design are kept well.

5.2 Time domain

The responses of the system with step distur-

ance are shown in Figs. 11–13. Figures 14–16 show the responses of the system with sine wave disturbance.

We can see that the active system has good performances. The heaving, pitching and rolling accelerations of the car body are reduced. The designed nonlinear adaptive controller can keep good performance of the H_∞ controller.

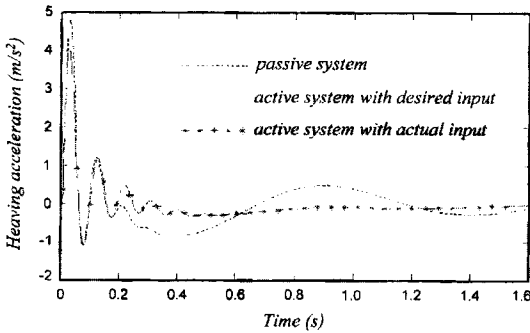

Fig. 11 Heaving acceleration of the car-body with step disturbance

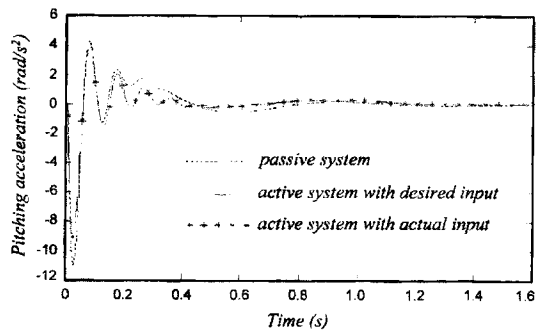

Fig. 12 Pitching acceleration of the car-body with step disturbance

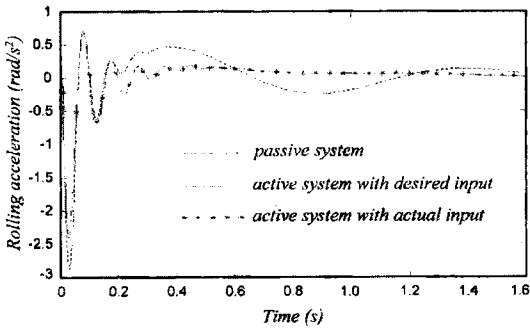

Fig. 13 Rolling acceleration of the car-body with step disturbance

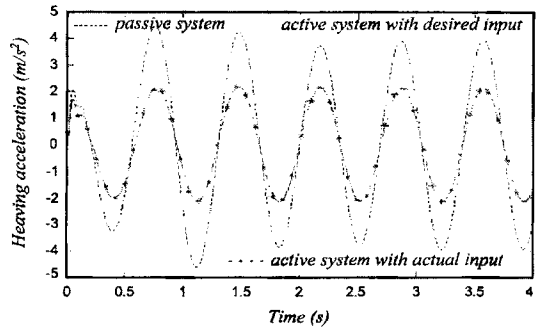

Fig. 14 Heaving acceleration of the car-body with sine wave disturbance

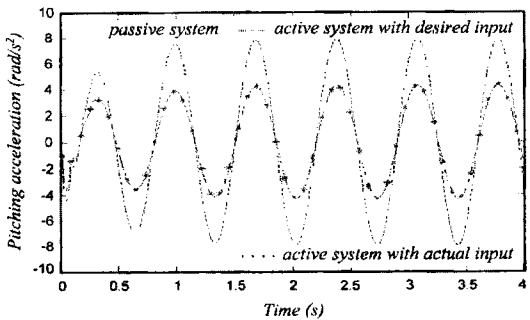

Fig. 15 Pitching acceleration of the car-body with sine wave disturbance

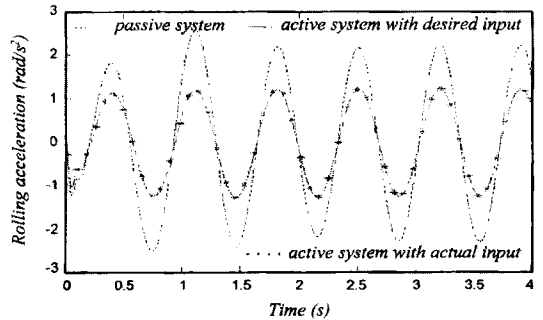

Fig. 16 Rolling acceleration of the car-body with sine wave disturbance

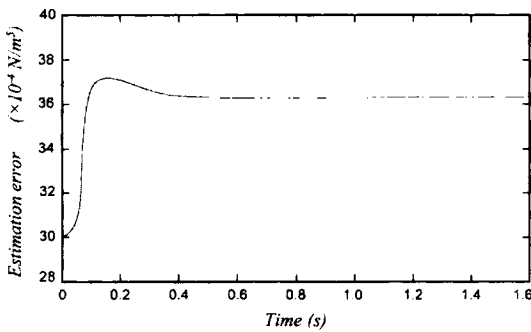

Fig. 17 Estimation error $\tilde{\theta}_1$

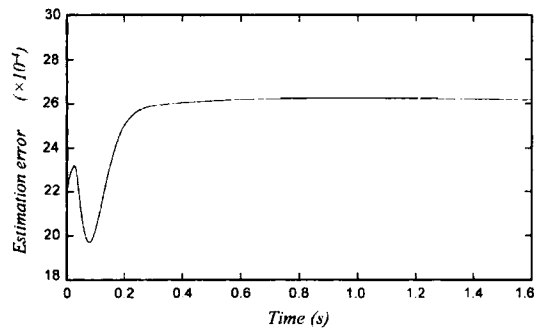

Fig. 18 Estimation error $\tilde{\theta}_2$

Figures 17 and 18 show the estimation errors $\tilde{\theta}_1$ and $\tilde{\theta}_2$, respectively. The errors between estimated values and actual values are very small.

6. Conclusions

This paper presents hybrid control of an active suspension system with full-car model by using H_∞ and nonlinear adaptive control methods. H_∞ controller achieved robustness in the presence of parameter uncertainties and minimized the effects of disturbance. The system parameter variations are taken into account by multiplicative uncertainty model and system robustness is guaranteed by small gain theorem. Simulation results show that the proposed controller yields better performance in the heaving, pitching and rolling accelerations of the car-body than the passive system in both time and frequency domains. And the designed nonlinear adaptive controller for hydraulic actuators can keep good performance of the H_∞ controller.

From the above results, the H_∞ controller can be used usefully to control an active suspension system because it meets two requirements :

- (1) good performance: small gains from road disturbance to the heaving, pitching and rolling accelerations of the car-body.
- (2) robustness property which is guaranteed from small gain theorem.

It is expected that the active suspension system with the proposed controller can be applied to car industry so that the car's quality could be improved.

References

Andrew Alleyne and J. Karl Hedrick, 1995, "Nonlinear Adaptive Control of Active Suspensions," *IEEE Transaction on Control Systems Technology*, Vol. 3, No. 1, pp. 94~101.

Bahram Shahian and Michael Hassul, 1993, *Control System Design Using Matlab*, Prentice-Hall International, Inc.

Doyle, J. C., Glover, K., Khargonekar, P. and Francis, B., 1989, "State-Space Solutions to Standard H_2 and H_∞ Control Problem," *IEEE Transaction on Automatic Control*, Vol. 34, No. 8, pp. 831~847.

Herbert E., 1967, *Merritt, Hydraulic Control Systems*, John Wiley & Sons, Inc.

Jong H. Park and Young S. Kim, 1998, "Decentralized Variable Structure Control for Active Suspensions Based on a Full-Car Model," *Proceeding of the 1998 IEEE, International Conference on Control Applications*, pp. 383~387, Italy.

Jung-Shan Lin and Ioannis Kanellakopoulos, 1997, "Nonlinear Design of Active Suspensions," *IEEE Control Systems Magazine*, Vol. 17, No. 3, pp. 45~59.

Katsuhisa Furuta, Akira Sano and Derek Atherton, 1988, *State Variable Methods in Automatic Control*, John Wiley & Sons, Inc.

Kemin Zhon and John C. Doyle, 1998, *Essentials of Robust Control*, Prentice-Hall International, Inc.

Krstic, M., Kanellakopoulos, I., and Kokotovic, P., 1995, *Nonlinear and Adaptive Control Design*, John Wiley & Sons, Inc.

Nguyen, T. T. 1998, "Control of Active Suspension System by Using H_∞ Theory," *MS. Thesis*, PKNU, Korea.

Nguyen, T. T., Nguyen, V. G. and Kim, S. B., 2000, "Control of Active Suspension System by Using H_∞ Theory," *ICASE Transaction on Control, Automation and System Engineering*, Vol. 2, No. 1, pp. 1~6.

Takanori Fukao, Arika Yamawaki and Norihiko Adachi, 1999, "Nonlinear and H_∞ Control of Active Suspension Systems with Hydraulic

Actuators," *Proceeding of the 38th Conference on Decision and Control*, pp. 5125~5128, Phoenix.

Thomas D. Gillespie, 1992, *Fundamentals of Vehicle Dynamics*, Society of Automotive Engineers, Inc.

Yong Ha Jung, Jae Weon Choi and Young Bong Seo, 2000, "Overlapping Decentralized EA Control Design for an Active Suspension System of a Full Car Model," *Proceeding of the SICE 2000*, pp. 85~90, Iizuka.